

FEATURES

- 1.8 V analog and digital core supply voltage**
- Correlated double sampler (CDS) with -3 dB, 0 dB, +3 dB, and +6 dB gain**
- 6 dB to 42 dB 10-bit variable gain amplifier (VGA)**
- 14-bit 65 MHz analog-to-digital converter**
- Black-level clamp with variable level control**
- Complete on-chip timing generator**
- Precision Timing* core with 240 ps resolution @ 65 MHz**
- On-chip 3 V horizontal and RG drivers**
- General-purpose outputs (GPOs) for shutter and system support**
- 7 mm × 7 mm, 48-lead LFCSP package**
- Internal LDO regulator circuitry**

APPLICATIONS

- Professional HDTV camcorders**
- Professional/high end digital cameras**
- Broadcast cameras**
- Industrial high speed cameras**

GENERAL DESCRIPTION

The AD9979 is a highly integrated CCD signal processor for high speed digital video camera applications. Specified at pixel rates of up to 65 MHz, the AD9979 consists of a complete analog front end with analog-to-digital conversion, combined with a programmable timing driver. The *Precision Timing* core allows adjustment of high speed clocks with approximately 240 ps resolution at 65 MHz operation.

The analog front end includes black-level clamping, CDS, VGA, and a 65 MSPS, 14-bit analog-to-digital converter. The timing driver provides the high speed CCD clock drivers for RG, HL, and H1 to H4. Operation is programmed using a 3-wire serial interface.

Available in a space-saving, 7 mm × 7 mm, 48-lead LFCSP package, the AD9979 is specified over an operating temperature range of -25°C to +85°C.

FUNCTIONAL BLOCK DIAGRAM

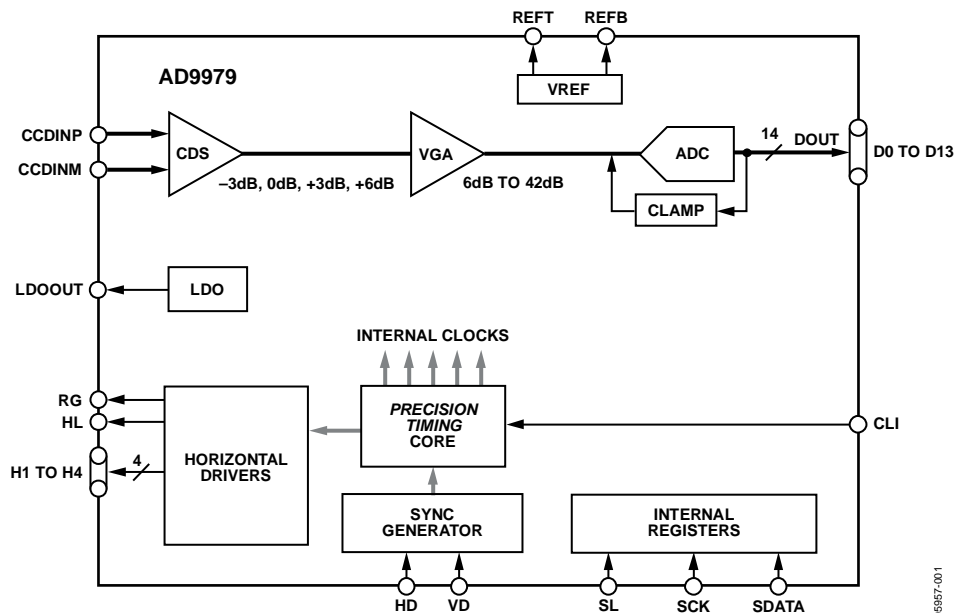

Figure 1.

Rev. Sp0

Information furnished by Analog Devices is believed to be accurate and reliable. However, no responsibility is assumed by Analog Devices for its use, nor for any infringements of patents or other rights of third parties that may result from its use. Specifications subject to change without notice. No license is granted by implication or otherwise under any patent or patent rights of Analog Devices. Trademarks and registered trademarks are the property of their respective owners.

AD9979